

Renal NSF Update

Donal O'Donoghue
National Clinical Director for Kidney care

Daisy Wild, Operational Research Analyst

The National Service Framework for Renal Services

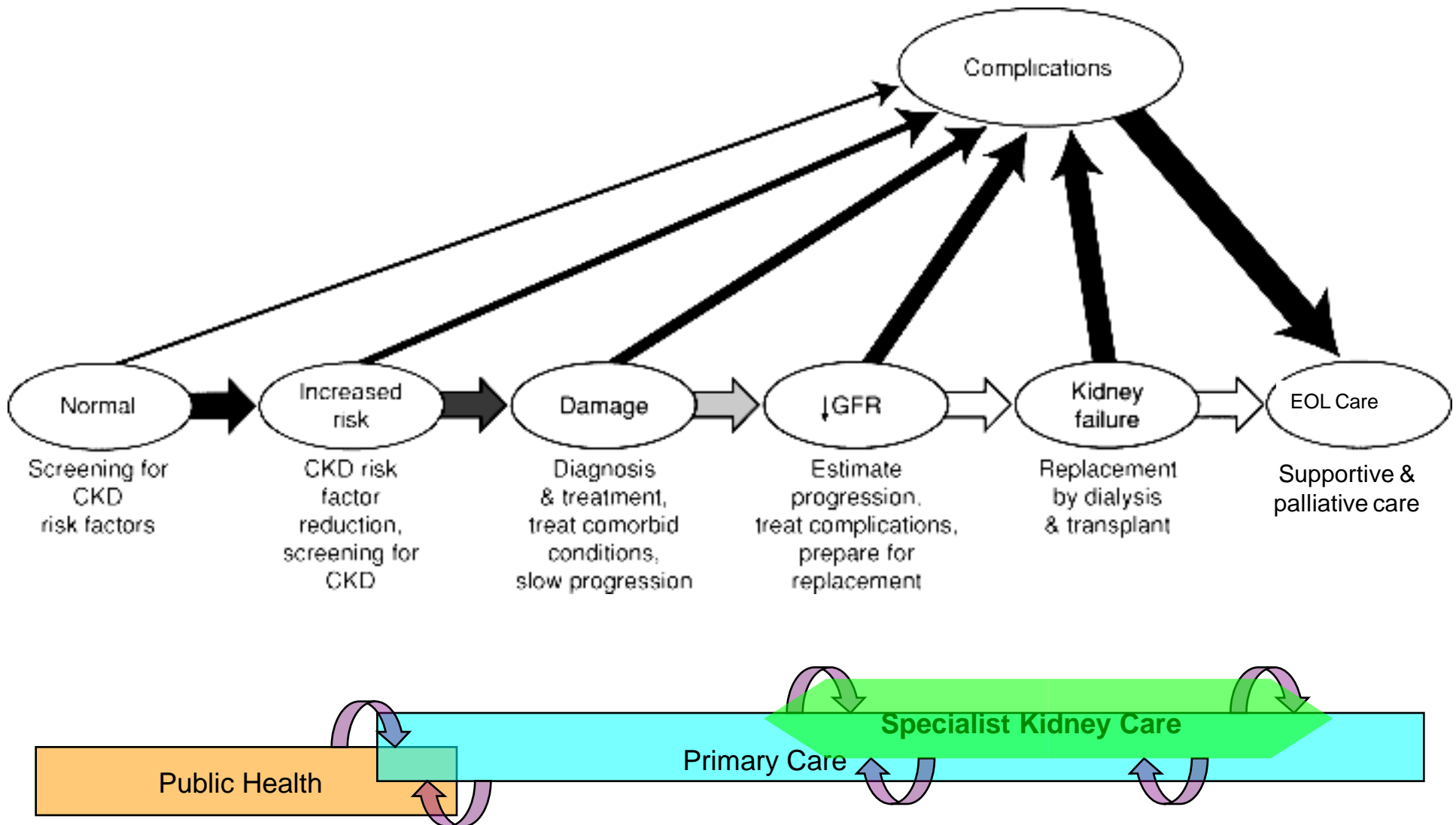

Renal Replacement Therapy Demand Modelling

Clinical Quality and Strategy Analytical Team
Daisy Wild

Background

- Demand for renal replacement therapy (RRT) in England has been increasing rapidly
- Modelling tool required to predict how demand is likely to change in the future in order to support capacity planning
- Model to operate at both a national and local level and enable “what if..” testing
- Tool to be distributed to specialist commissioning groups (SCGs) for local planning
- Support from the Renal Registry
- Input from SCG representatives on their requirements
- Project steering group with range of expertise providing challenge and advice to ensure model is robust and useful

Model

- Dynamic simulation model with Excel interface for data input and results
- Represents the alternative treatment modes of RRT and tracks over time the number of people (adults only) being taken onto RRT, moving between modes (including receiving kidney transplants) and dying
- 10 year time horizon
- Estimates the costs of providing the volume of treatment predicted

Basic model structure

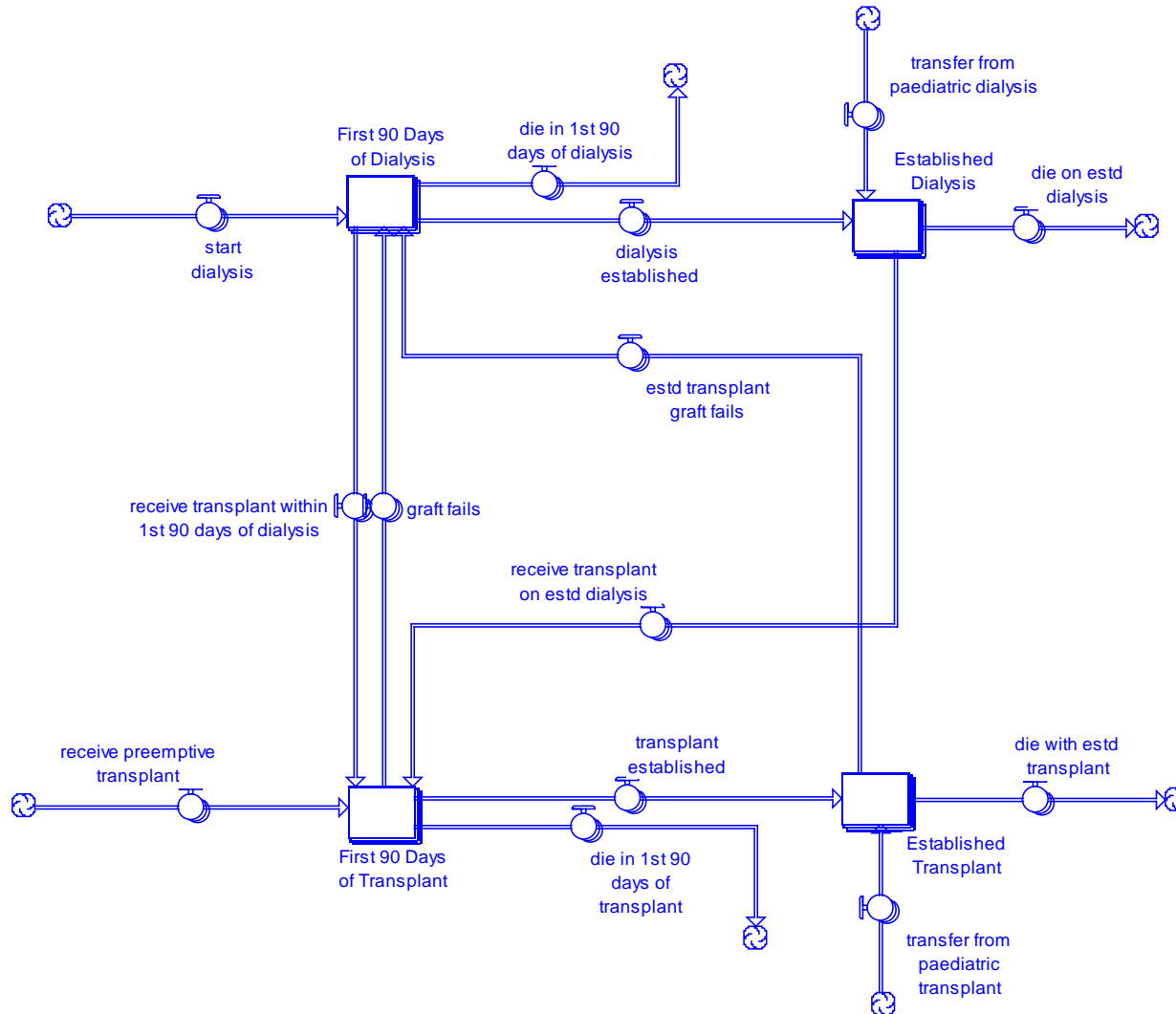

Model segmentation

Geography

- Basic unit in model is local authority
- Flexibility to aggregate to SHA or England level or assigned renal centre

Age bands

- Model data and parameters disaggregated into four age bands:
 - 18 to 44
 - 45 to 64
 - 65 to 74
 - 75+
- Appropriate proportions of patients move between the age bands each year

Ethnicity

- Take-on estimated independently for white and BME populations
- Transplant rates also dependent on this

Mode of dialysis

- Model keeps track of the number of patients receiving each type of dialysis:
 - HD centre
 - Home HD
 - PD

Populating the model

Starting levels of RRT patients

- Numbers of adult dialysis (HD centre, home HD and PD) and transplant patients at 1 January 2008 grouped by local authority and age band

Take-on rates

- Current RRT acceptance rates estimated for white and BME populations by age band

Population projections

- Annual estimates for 2008 to 2018 produced for each local authority by age band and ethnicity

Transplant rates

- Annual national transplant projections from live and deceased donors to be confirmed
- Age/ethnicity group relative chances of receiving a transplant estimated from 2007 transplant data

Mortality rates

- Annual mortality rates estimated for prevalent established dialysis and transplant patients by age band (based on 2007 data)
- Mortality rates in first three months of receiving dialysis or a transplant estimated by age band

Transfer rates between RRT modes

- Rates of transfer between alternative dialysis treatments estimated for each age band (based on 2006 and 2007 data)
- Rates of transplant failure and reversion to dialysis estimated by age band (also 2006 and 2007 data)

Take-on rates

- Annual RRT acceptance rates estimated for each age band for each year between 2000 and 2007 based on areas covered by Renal Registry in each year (97% of PCTs covered in 2007) using new patient data compared with ONS population estimates
- Relative risk of being accepted for RRT of the BME population compared with whites estimated using:
 - 2004 to 2007 new patient data for local authorities with complete coverage and complete ethnicity coding in Renal Registry
 - ONS “experimental population estimates” by age group and ethnicity for the corresponding years and local authorities
- Relative risk estimates applied to estimated 2007 acceptance rates in relation to the respective population sizes to derive acceptance rates for white and BME populations

Provisional estimates

Age band	2007 acceptance rates pmp
18-44	49
45-64	147
65-74	317
75+	317
All (inc children)	111

Age band	BME relative risk of RRT (confidence interval)	
18 - 44	1.8	(1.6-2.0)
45-64	3.6	(3.3-4.0)
65-74	4.2	(3.8-4.6)
75+	3.8	(3.3-4.4)
All adults	2.8	(2.7-2.9)

Age band	Acceptance rates pmp	
	White	BME
18-44	44	78
45-64	123	447
65-74	273	1,142
75+	294	1,117

Historic and modelled overall take-on rates (provisional base case)

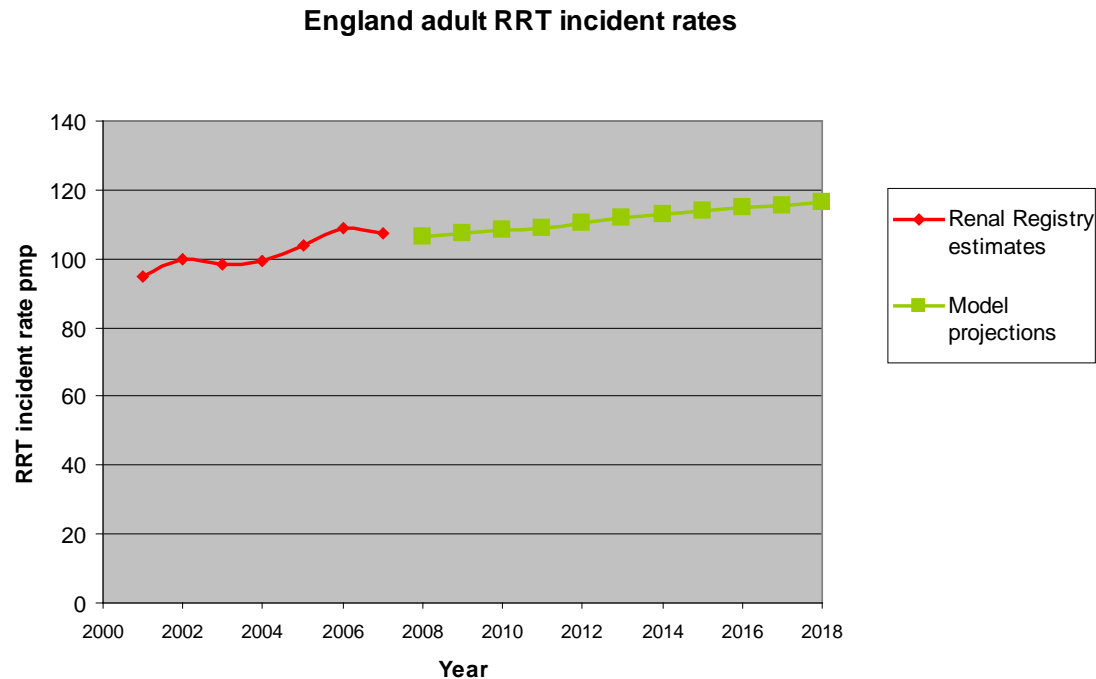

- Assumes ethnic specific acceptance rates remain at 2007 levels and therefore does not include the effect of increasing diabetes prevalence or other drivers of ESRF beyond what is explained by ageing and the increase in the ethnic minority population
- Overall RRT take-on rates are projected to increase as the population ages and the proportion of ethnic minorities increases

Modelled vs observed adult RRT patients in England

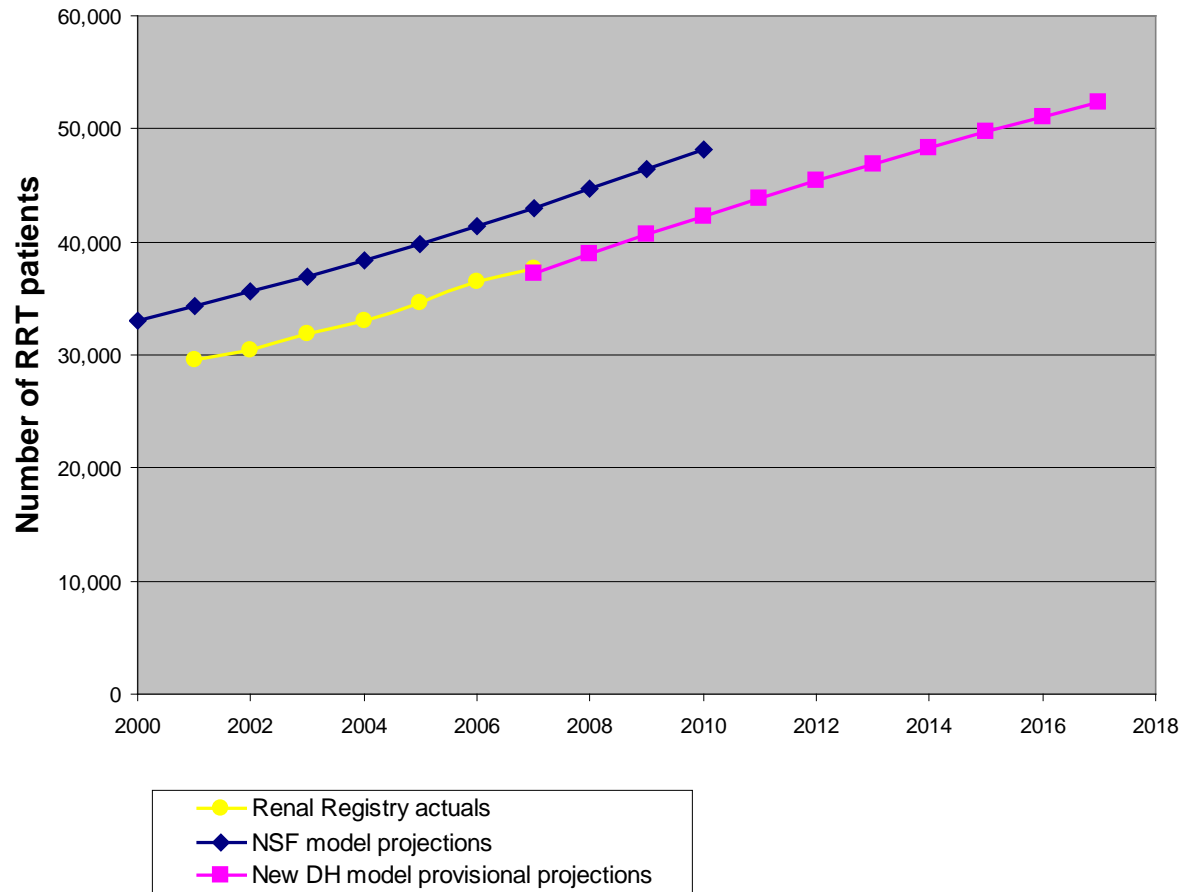

Notes:

1. The starting point in the NSF model base case was too high due to an overestimated prevalence of RRT in 2000 (derived from a survey) but the growth rates it predicted are very close to those so far observed (~4% per annum).

2. The slight discrepancy between the Renal Registry volume for 2007 and that used in the new DH model is due to a difference in the national definition: the Renal Registry estimate includes all patients registered at a centre within England whereas the new DH model only covers individuals residing within England.

Emerging national results (subject to change)

RRT demand projections (adults only) – current survival rates and transplant rates

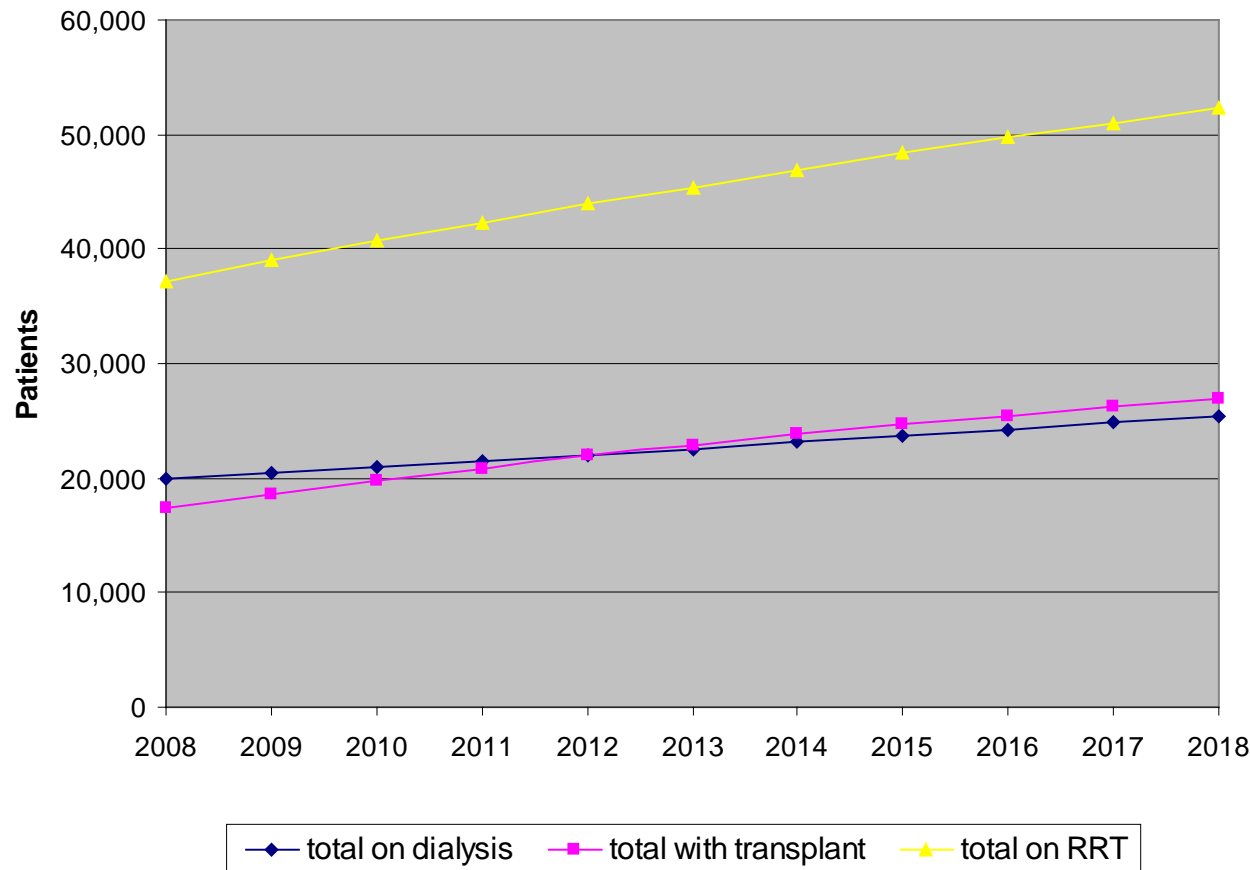

Assumes

- Age/ethnicity specific acceptance rates remain at current levels
- Mortality rates remain at current levels
- Transplant rates remain at current levels

Emerging national results (subject to change)

RRT demand projections (adults only) – 50% increase in cadaver transplants

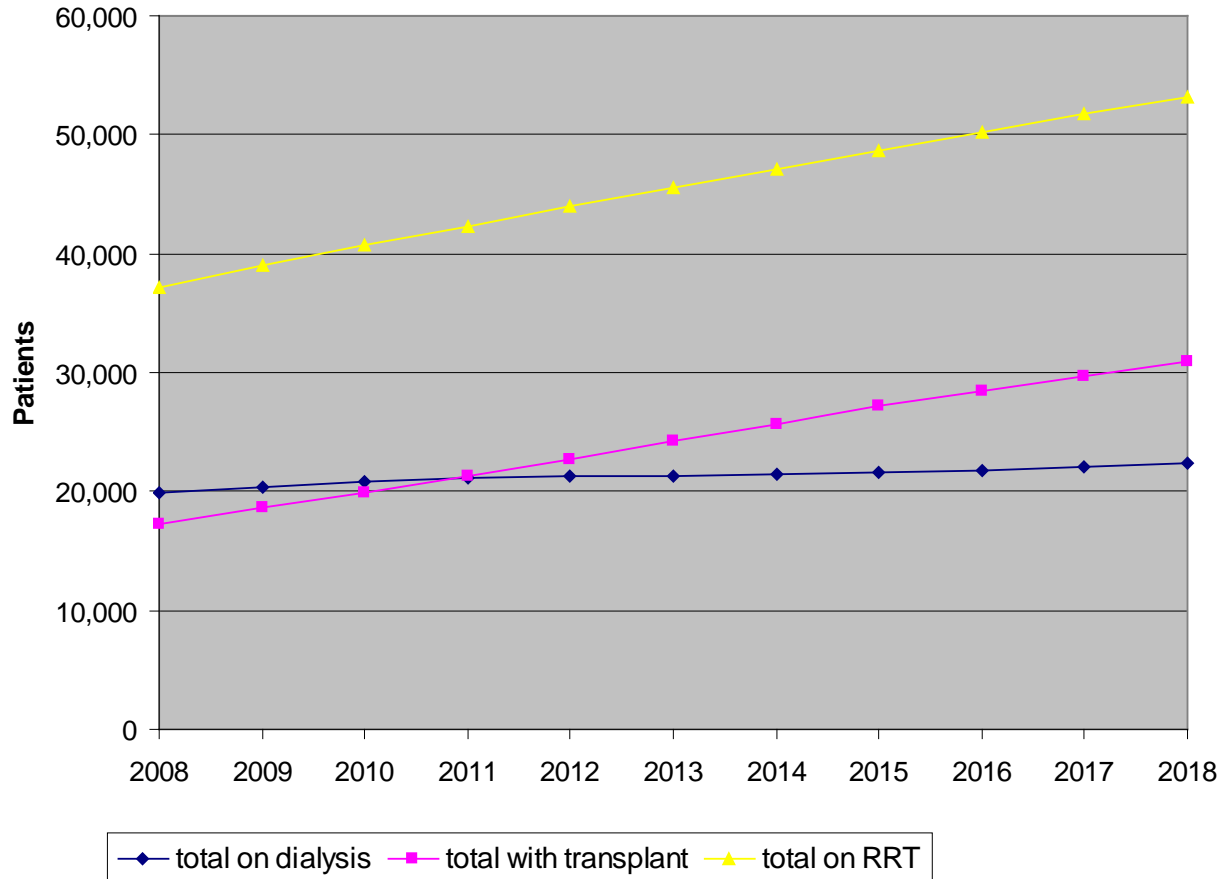

Assumes

- Age/ethnicity specific acceptance rates remain at current levels
- Mortality rates remain at current levels
- Cadaveric transplants increase by 50% over the next five years

Timetable

- Draft model for testing mid April
- Final model to be distributed to Specialist Commissioning Groups in May
- Model to be updated annually and refined/extended as appropriate

Toward a best practice tariff for dialysis

Donal O'Donoghue
National Clinical Director for Kidney care

National Schedule of Reference Costs 2006-07 - NHS Trusts

Renal Dialysis Services

HRG Code	HRG Label	No. of Sessions	National Average Unit Cost £	Interquartile Range of Unit Costs ²		No. of Data Submissions
				Lower Quartile £	Upper Quartile £	
LC01A	Haemodialysis/Filtration on patient with Hep B 19 years and over	211,299	175	134	178	21
LC01B	Haemodialysis/Filtration on patient with Hep B 19 years and under	2,666	99	142	184	5
LC02A	Haemodialysis/Filtration 19 years and over	1,854,429	158	133	197	52
LC02B	Haemodialysis/Filtration 18 years and under	32,293	216	112	311	17
LC03A	Peritoneal Dialysis on patient with Hepatitis B 19 years and over	313,620	41	27	48	12
LC03B	Peritoneal Dialysis on patient with Hepatitis B 18 years and under	7,450	40	34	52	3
LC04A	Peritoneal Dialysis 19 years and over	1,661,522	44	28	68	44
LC04B	Peritoneal Dialysis 18 years and under	71,743	114	74	267	13

1. Dialysis is high cost
2. 2006-07 reference costs highlighted large differences between units

For haemodialysis in patient 19 years and over:

average sessional cost = £158; interquartile range = £133 - £197

interquartile range of annual cost of 3 x weekly haemodialysis = £20,748 – £30,732

PbR for Kidney Dialysis Project Group

- established October 2007 with support from PbR Clinical Advisory Panel and Renal Advisory Group
- analysed data from 16 Trusts, reconciling individual Trust data submissions based on the 2007 National Schedule of Reference Costs collection exercise with the actual data received by the Project Group
- Project Group produced a checklist to help inform and improve the preparation of 2008 reference costs
- participant Trusts shared their provisional 2008 reference cost submissions in September 2008 prior to formal submission

2006/07 and 2007/08 LC02A Haemodialysis/Filtration 19 years and over

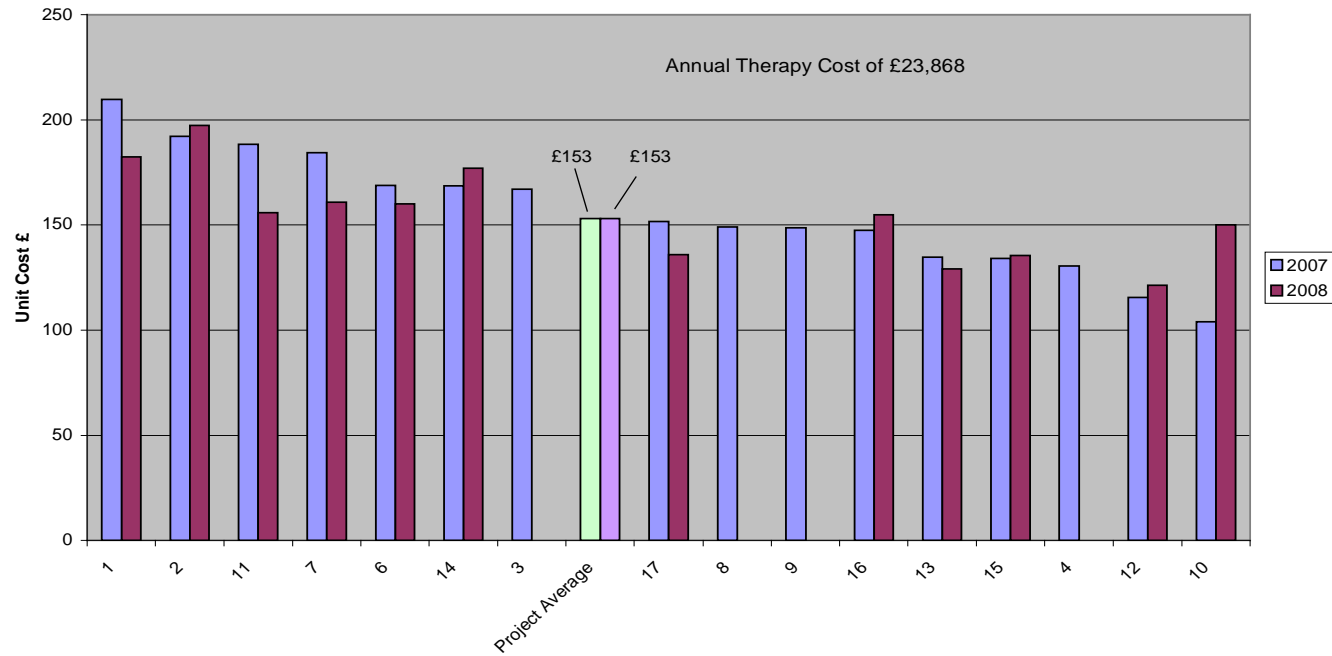

2006/07 and 2007/08 LC04A Peritoneal Dialysis 19 years and over

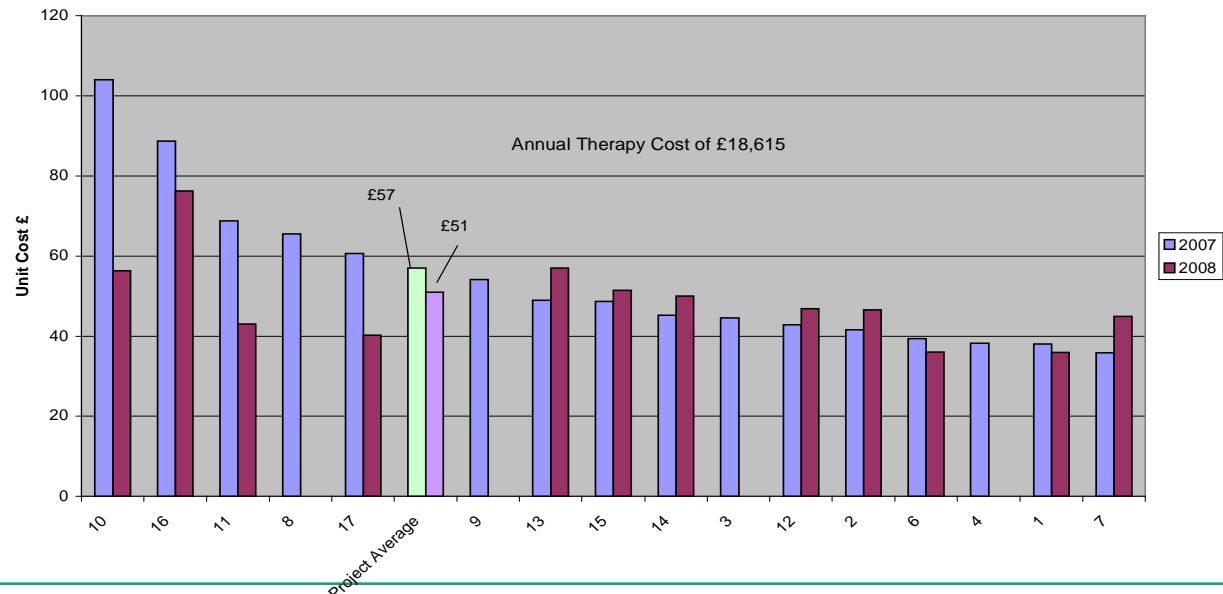

Timely Vascular Access

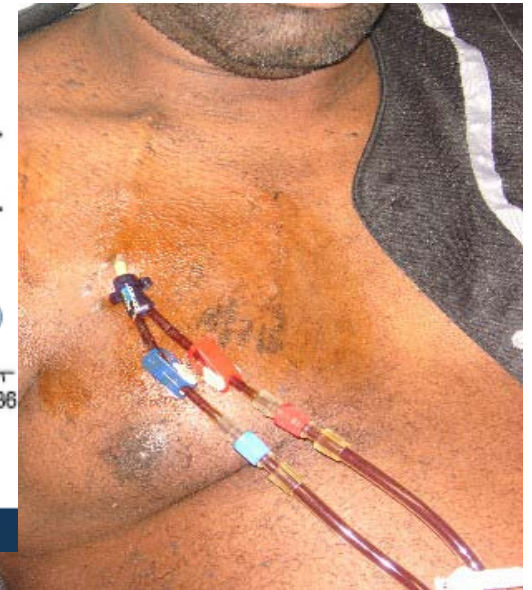
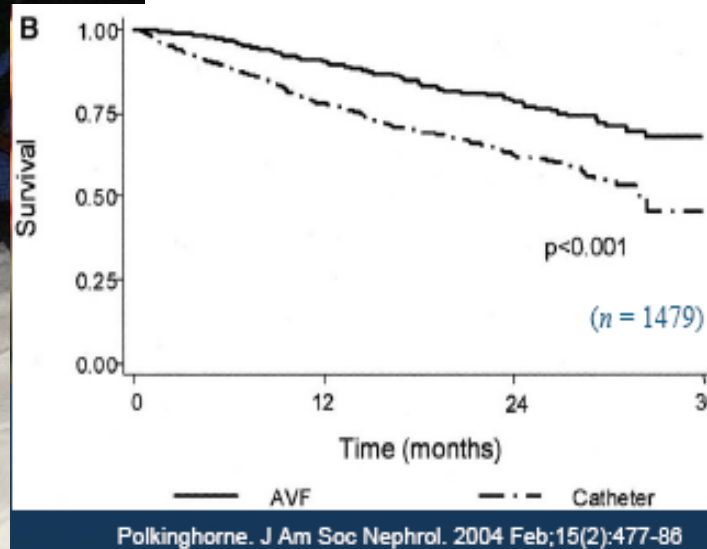
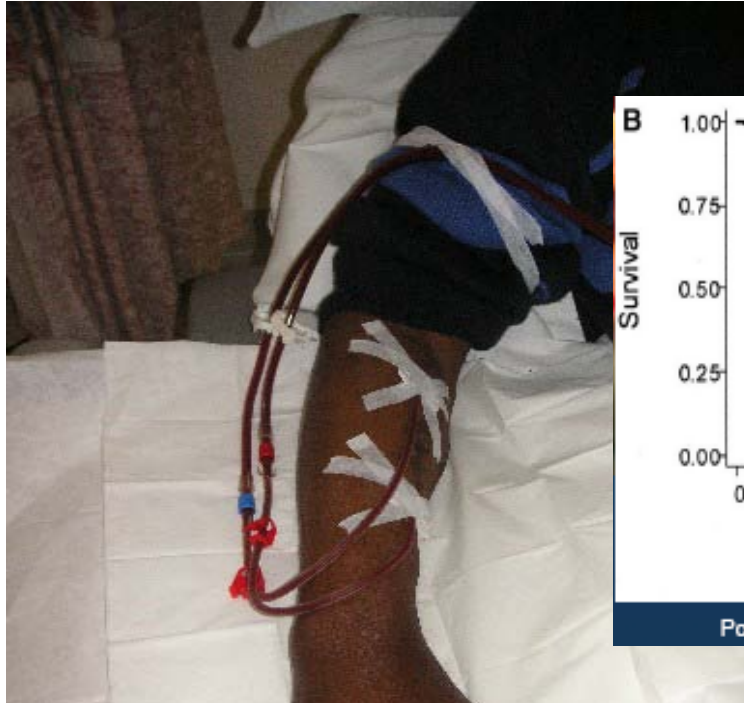

Standard 3

“All children, young people and adults with established renal failure are to have timely and appropriate surgery for permanent vascular or peritoneal dialysis access, which is monitored and maintained to achieve its maximum longevity.”

MRSA in the dialysis population

Risk: 100 fold higher incidence than general population
800 fold higher incidence for those using a venous catheter

Variability by centre
England

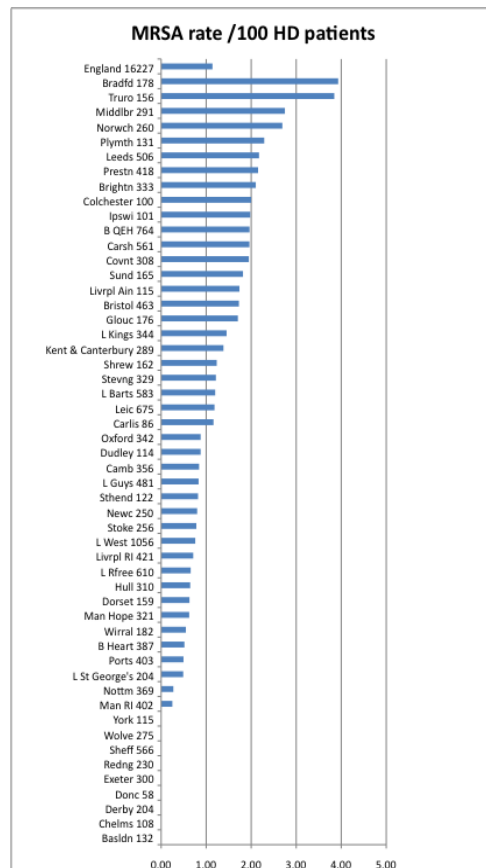

Improvement across England
Episodes/ year

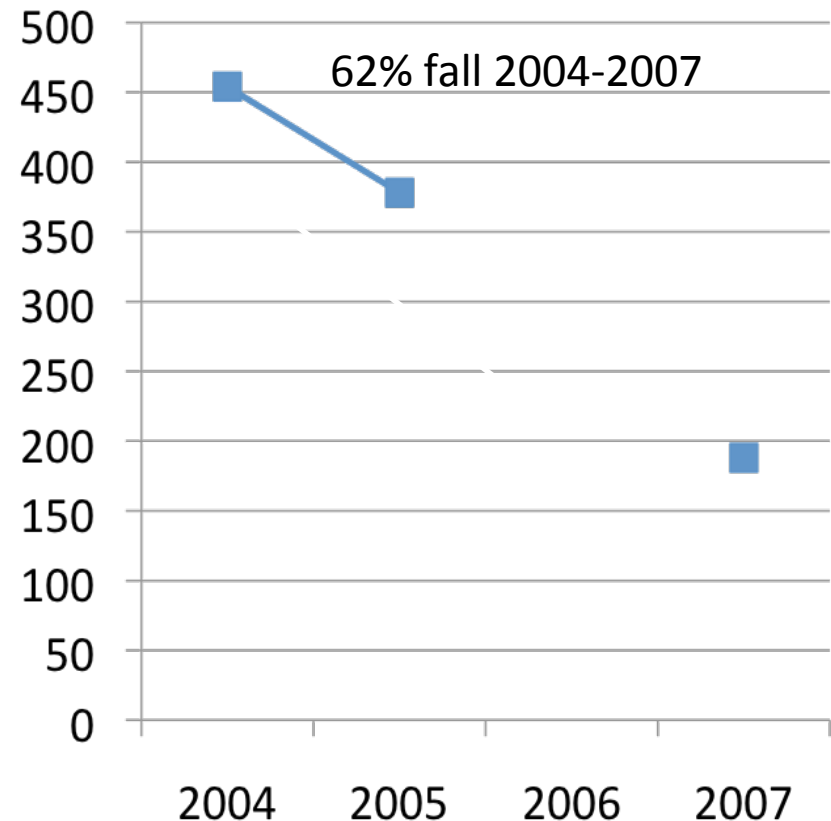

Data taken from **Epidemiology of methicillin-resistant staphylococcus aureus bacteraemia amongst patients receiving Renal Replacement Therapy in England in 2007: a joint report from the UK Renal Registry and the Health Protection Agency** (The Eleventh Renal Registry Report), Nature Clinical Practice, 2009, in press

Best Practice Tariff for Kidney Care:

- Incentivise Primary Care – including training – to manage patients as long as appropriate
- Transfer to secondary care at appropriate time for the patient
- Conservative Kidney Care Option for non dialysis treatment
- Choice of Modality
- Pre-Emptive Listing for Kidney Transplantation
- Graft formation in Preparation for Dialysis
- Renal Patient View – Taken account of throughout the pathway

Clinical Practice Guidelines

- provide a template for the management of patients with kidney disease in the UK
- define the data collected by the Renal Registry
- current 4th edition published in modular form between April 2007 and April 2008
- guidelines on facilities; equipment and consumables; dialysis dose, frequency and adequacy; laboratory and clinical indices; infection; vascular access for haemodialysis; access to and withdrawal from dialysis

National Renal Dataset

- renal medicine first specialty to be bound by a legal requirement to record patient data
- defines the information required to support the implementation of the National Service Framework (NSF) for Renal Services
- existing collections by the UK Renal Registry form part of this dataset
- implementation is effective from 31 May 2009 for 693 mandatory items – including data relating to anaemia and dialysis access, frequency, and adequacy

Best Practice Tariffs for renal dialysis

PbR for Kidney Dialysis Project Group

- engagement with renal community



Information Standards Board
for Health and Social Care
IMPLEMENTABILITY INTEROPERABILITY SAFETY

Clinical Practice Guidelines

UK Renal Registry

National Renal Data Set